

RSO118CQ120 • RSO118CQ120BL • RSO118CQ120BLS

Ballast Type: Electronic
Input Voltage: 120VAC ±10%
Input Frequency: 50/60 Hz.

Starting Method: Preheat Rapid Start
Lamp Connection: Series
Unit Color: White

Unit Weight: 0.52 lb
Carton Quantity: 50/40/40
Skid Quantity: 2250/1440/1440

ELECTRICAL SPECIFICATION:

Line Voltage (V)	Lamp Type	Lamp Watts	No. of Lamps	Line Current (A)	Input Power (W)	Power Factor	Max Current THD (%)	Current Crest Factor	Ballast Factor	Wiring Diagram	B.E.F.
120	CFQ18W/G24q CFTR18W/GX24q	18	1	0.29	18	≥0.52	≤148	≤1.4	0.98	103	5.44
120	CFS21W/GR10q	21	1	0.29	19	≥0.52	≤150	≤1.4	0.91	122	4.79
120	FC8T9	22	1	0.29	18	≥0.50	≤150	≤1.5	0.98	61	5.44

PERFORMANCE:

- Electronic ballast
- Preheat rapid start ballast
- Series operation
- Normal power factor
- Encased & potted
- End-of-Lamp Life protection
- Internal surge protection
- Sound rated A
- Meets FCC Part 18 (Class B) EMI and RFI consumer limits
- Meets ANSI standard C82.11 (where applicable)
- Meets ANSI standard C62.41

APPLICATION:

- Maximum case temperature: 194°F/90°C
- Maximum ambient temperature: 104°F/40°C
- Minimum starting temperature: -4°F/-20°C
- Not recommended for extreme temperature variations
- Lamp starts: >15,000 starts
- Remote mounting: 18 ft.

SAFETY:

- UL/935 (Class P, Type HL, Type CC, Type 1 outdoor) listed
- CSA (cUL) certified
- Inherent Thermal Protection
- RoHS Compliant
- No PCB's

ORDERING INFORMATION:

- Side Leads - No Suffix
- Bottom Leads - BL
- Bottom Leads w Studs - BLS

STYLE:

7E

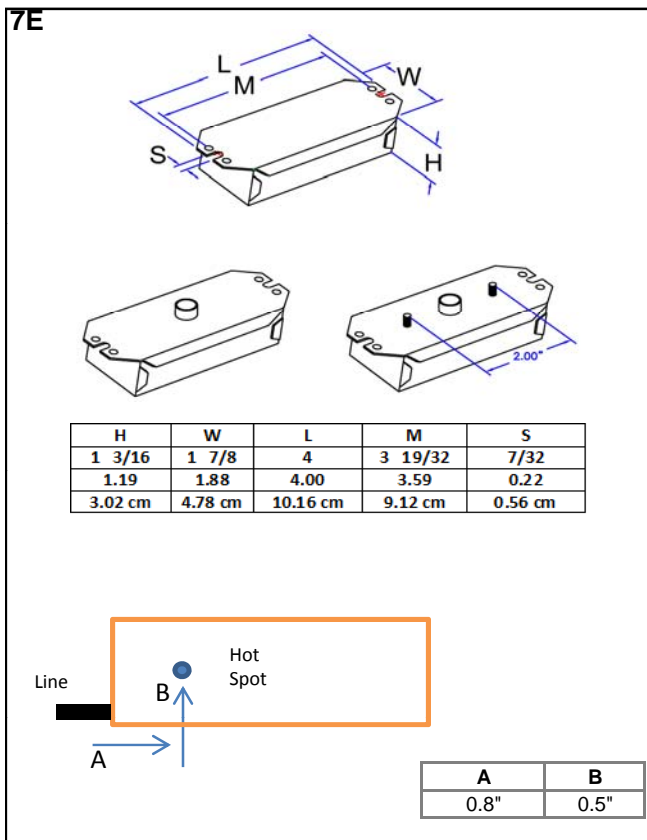

H	W	L	M	S
1 3/16	1 7/8	4	3 19/32	7/32
1.19	1.88	4.00	3.59	0.22
3.02 cm	4.78 cm	10.16 cm	9.12 cm	0.56 cm

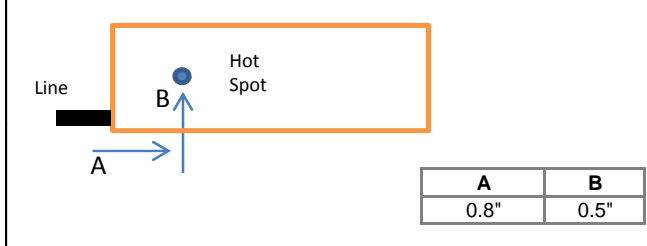

A	B
0.8"	0.5"

WARRANTY:

Robertson Worldwide warrants to the purchaser that this ballast will be free from defects in material or workmanship for a period of 2 years from date of manufacture when properly installed and under normal conditions of use. For more information on Robertson Worldwide ballasts, call 1-800-323-5633 or visit www.robertsonww.com. For our energy star compliant ballasts, visit www.nema.org/lampballastmatrix/ Specifications subject to change without notice.

Revised 10/21/11

WIRING DIAGRAM:

61

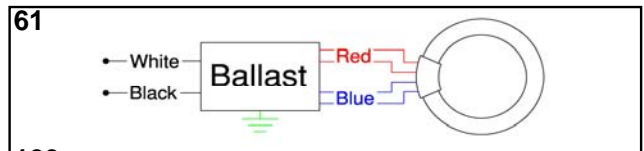

103

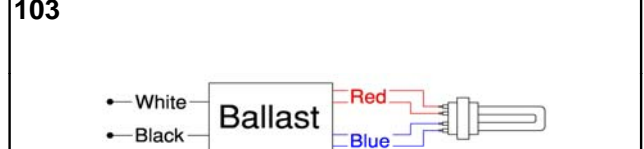

122



Standard lead lengths:

- Blk: 12"
- Wht: 12"
- Red: (2) 12"
- Blu: (2) 12"

* 3/8 Strip

Lead lengths for Part Numbers ending in "BL" and "BLS": 10"