

Features

- High Efficiency (Up to 90.5%)
- Full Power at 50-100% Max Current (Constant Power)
- 0-10V/PWM/Timer Dimmable (3 Timer Modes)
- Dim-to-Off with Standby Power ≤ 1.5 W
- Output Lumen Compensation
- Input Surge Protection: 4kV line-line, 6kV line-earth
- All-Around Protection: OVP, SCP, OTP
- Suitable for UL Dry / Damp / Wet Location
- Class 2 Output
- TYPE HL, for use in a Class I, Division 2 hazardous (Classified) location



Description

The ESD-096SxxxDT series is a 96W, constant-current, programmable LED driver that operates from 249-528 Vac input with excellent power factor. Created for low bay, area and street lights, it provides a dim-to-off mode with low standby power. The high efficiency of these drivers and compact metal case enables them to run cooler, significantly improving reliability and extending product life. To ensure trouble-free operation, protection is provided against input surge, output over voltage, short circuit, and over temperature.

Models

Adjustable Output Current Range	Full-Power Current Range (1)	Default Output Current	Input Voltage Range	Output Voltage Range	Max. Output Power	Typical Efficiency (2)	Power Factor		Model Number
							277Vac	480Vac	
45-900mA	450-900mA	700 mA	249~528 Vac	64~214Vdc	96 W	90.5%	0.98	0.95	ESD-096S090DT
90-1800mA	900-1800mA	1050 mA	249~528 Vac	32~107Vdc	96 W	90.5%	0.98	0.95	ESD-096S180DT
180-3600mA	1800-3600mA	2100 mA	249~528 Vac	16 ~ 53Vdc	96 W	89.5%	0.98	0.95	ESD-096S360DT ⁽³⁾

- Notes:** (1) Output current range with constant power at 96W
 (2) Measured at a 480 Vac input with 50% output current and 100% output voltage.
 (3) Class 2 output

I-V Operating Area

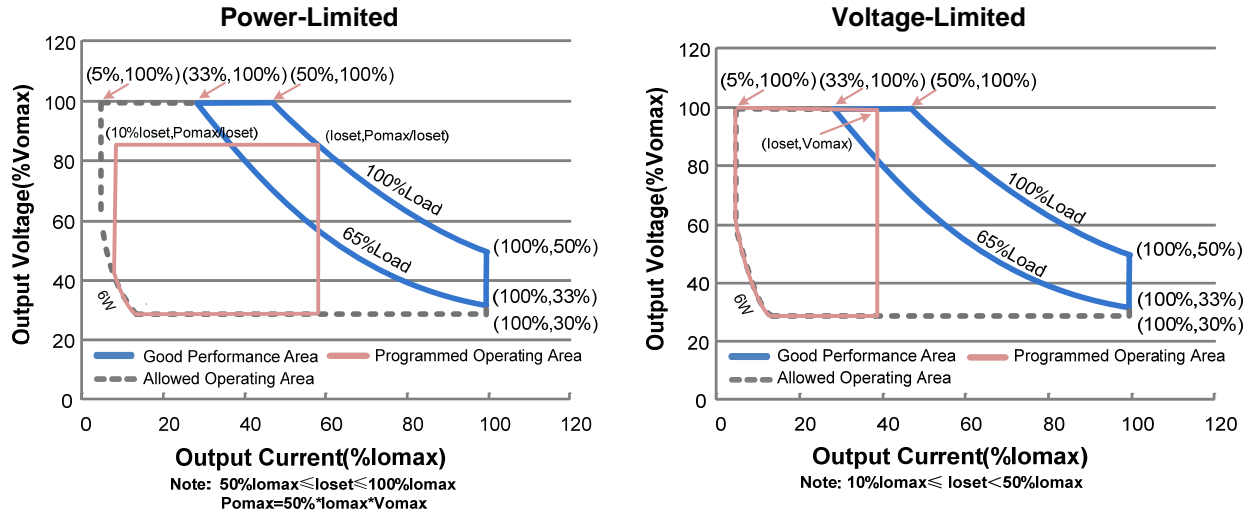

Input Specifications

Parameter	Min.	Typ.	Max.	Notes
Input Voltage	249 Vac	-	528 Vac	
Input Frequency	47 Hz	-	63 Hz	
Leakage Current	-	-	1.0 mA	At 480Vac 60Hz input; Grounding effectively.
Input AC Current	-	-	0.48A	Measured at full load and 277 Vac input.
	-	-	0.30A	Measured at full load and 480 Vac input.
Inrush Current(I ² t)	-	-	2.17 A ² s	At 480Vac input, 25°C Cold Start, Duration=500 uS, 10%I _{pk} -10%I _{pk} . See Inrush Current Waveform for the details.
PF	0.90	-	-	At 277-480Vac, 50-60Hz, 65%-100%Load (63-96W)
THD	-	-	20%	

Output Specifications

Parameter	Min.	Typ.	Max.	Notes
Output Current Tolerance	-5%I _{oset}	-	5%I _{oset}	At full load condition
Output Current Setting(I _{oset}) Range	10%I _{omax}	-	100%I _{omax}	
Output Current Setting Range with Constant Power	50%I _{omax}	-	100%I _{omax}	
Total Output Current Ripple (pk-pk)	-	5%I _{omax}	10%I _{omax}	At full load condition, 20 MHz BW
Output Current Ripple at < 200 Hz (pk-pk)	-	1%I _{omax}	-	At full load condition. Only this component of ripple is associated with visible flicker.
Startup Overshoot Current	-	-	10%I _{omax}	At full load condition

Output Specifications (Continued)

Parameter	Min.	Typ.	Max.	Notes
No-load Output Voltage ESD-096S090DT ESD-096S180DT ESD-096S360DT	- - -	- - -	240V 119V 59.5V	
Line Regulation	-	-	±0.5%	Measured at full load
Load Regulation	-	-	±1.5%	
Turn-on Delay Time	-	1.0 s	2.0 s	Measured at 277Vac and 480Vac input , 65%-100%Load
Temperature Coefficient of I _o set	-	0.03%/°C	-	Case temperature = 0°C ~T _c max
12V Auxiliary Output Voltage	10.8 V	12 V	13.2 V	
12V Auxiliary Output Source Current	0 mA	-	200 mA	Return terminal is "Dim"

Note: All specifications are typical at 25°C unless otherwise stated.

General Specifications

Parameter	Min.	Typ.	Max.	Notes
Efficiency at 277 Vac input: ESD-096S090DT I _o =450 mA I _o =900 mA ESD-096S180DT I _o =900 mA I _o =1800mA ESD-096S360DT I _o =1800mA I _o =3600mA	87.5% 87.5% 87.5% 87.0% 86.0% 85.0%	89.5% 89.5% 89.5% 89.0% 88.0% 87.0%	- - - - - -	Measured at full load and steady-state temperature in 25°C ambient; (Efficiency will be about 2.0% lower if measured immediately after startup.)
Efficiency at 347 Vac input: ESD-096S090DT I _o =450 mA I _o =900 mA ESD-096S180DT I _o =900 mA I _o =1800mA ESD-096S360DT I _o =1800mA I _o =3600mA	88.0% 88.0% 88.0% 87.5% 87.0% 86.0%	90.0% 90.0% 90.0% 89.5% 89.0% 88.0%	- - - - - -	Measured at full load and steady-state temperature in 25°C ambient; (Efficiency will be about 2.0% lower if measured immediately after startup.)
Efficiency at 480 Vac input: ESD-096S090DT I _o =450 mA I _o =900 mA ESD-096S180DT I _o =900 mA I _o =1800mA ESD-096S360DT I _o =1800mA I _o =3600mA	88.5% 88.5% 88.5% 88.0% 87.5% 86.0%	90.5% 90.5% 90.5% 90.0% 89.5% 88.0%	- - - - - -	Measured at full load and steady-state temperature in 25°C ambient; (Efficiency will be about 2.0% lower if measured immediately after startup.)
Standby power	-	-	1.5 W	Measured at 480Vac/60Hz; Dimming off
MTBF	-	211,000 Hours	-	Measured at 480Vac input, 80%Load and 25°C ambient temperature (MIL-HDBK-217F)

General Specifications

Parameter	Min.	Typ.	Max.	Notes
Lifetime	-	103,000 Hours	-	Measured at 480Vac input, 80%Load and 60°C case temperature; See lifetime vs. Tc curve for the details
Operating Case Temperature for Safety Tc_s	-40°C	-	+90°C	
Operating Case Temperature for Warranty Tc_w	-40°C	-	+70°C	
Storage Temperature	-40°C	-	+85°C	Humidity: 5%RH to 100%RH
Dimensions Inches (L × W × H) Millimeters (L × W × H)	8.35 × 2.66 × 1.44 212 × 67.5 × 36.5			With mounting ear 9.41 × 2.66 × 1.44 239 × 67.5 × 36.5
Net Weight	-	1090 g	-	

Note: All specifications are typical at 25°C unless otherwise stated.

Dimming Specifications

Parameter	Min.	Typ.	Max.	Notes
Absolute Maximum Voltage on the Vdim (+) Pin	-20 V	-	20 V	
Source Current on Vdim (+) Pin	200 uA	300 uA	450 uA	Vdim(+) = 0 V
Dimming Output Range	10%loset	-	loset	50%lomax ≤ loiset ≤ 100%lomax
	5%lomax	-	loset	10%lomax ≤ loiset < 50%lomax
Recommended Dimming Input Range	0 V	-	10 V	Default 0-10V dimming mode.
Dim off Voltage	0.4 V	0.55V	0.7 V	
Dim on Voltage	0.6 V	0.75 V	0.9 V	
Hysteresis	-	0.2 V	-	
PWM_in High Level	3 V	-	10 V	Dimming mode set to PWM in PC interface.
PWM_in Low Level	-0.3 V	-	0.6 V	
PWM_in Frequency Range	200 Hz	-	3 KHz	
PWM_in Duty Cycle	1%	-	99%	
PWM Dimming off (Positive Logic)	3%	5%	8%	
PWM Dimming on (Positive Logic)	5%	7%	10%	
PWM Dimming off (Negative Logic)	92%	95%	97%	
PWM Dimming on (Negative Logic)	90%	93%	95%	
Hysteresis	-	2%	-	

Safety & EMC Compliance

Safety Category	Standard
UL/CUL	UL 8750,UL1310,CAN/CSA-C22.2 No. 250.13,CAN/CSA-C22.2 No. 223-M91
EMI Standards	Notes
FCC Part15 ⁽¹⁾	ANSI C63.4 Class B This device complies with Part 15 of the FCC Rules. Operation is subject to the following two conditions: [1] this device may not cause harmful interference, and [2] this device must accept any interference received, including interference that may cause undesired operation.
EMS Standards	Notes
EN 61000-4-2	Electrostatic Discharge (ESD): 8 kV air discharge, 4 kV contact discharge
EN 61000-4-3	Radio-Frequency Electromagnetic Field Susceptibility Test-RS
EN 61000-4-4	Electrical Fast Transient / Burst-EFT
EN 61000-4-5	Surge Immunity Test: AC Power Line: line to line 4 kV, line to earth 6 kV
EN 61000-4-6	Conducted Radio Frequency Disturbances Test-CS
EN 61000-4-8	Power Frequency Magnetic Field Test
EN 61000-4-11	Voltage Dips
EN 61547	Electromagnetic Immunity Requirements Applies To Lighting Equipment

Note: (1) This LED driver meets the EMI specifications above, but EMI performance of a luminaire that contains it depends also on the other devices connected to the driver and on the fixture itself.

Lifetime vs. Case Temperature

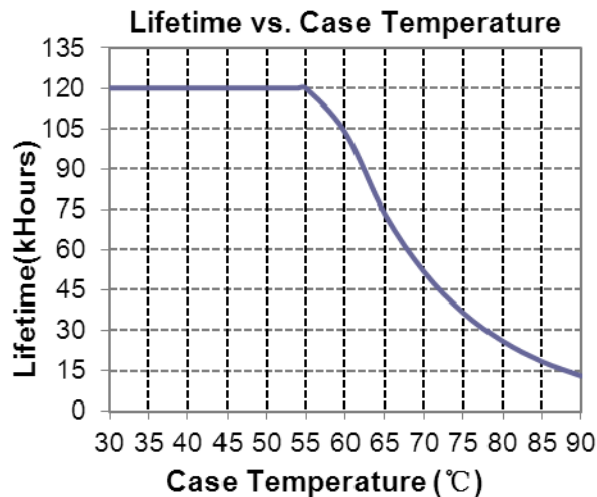

Inrush Current Waveform

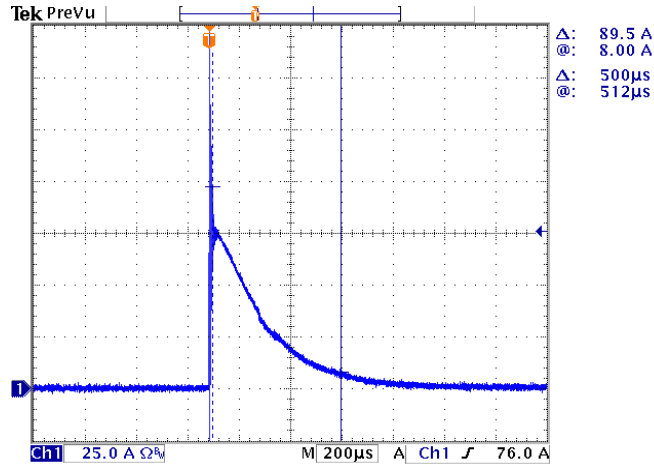

Efficiency vs. Load

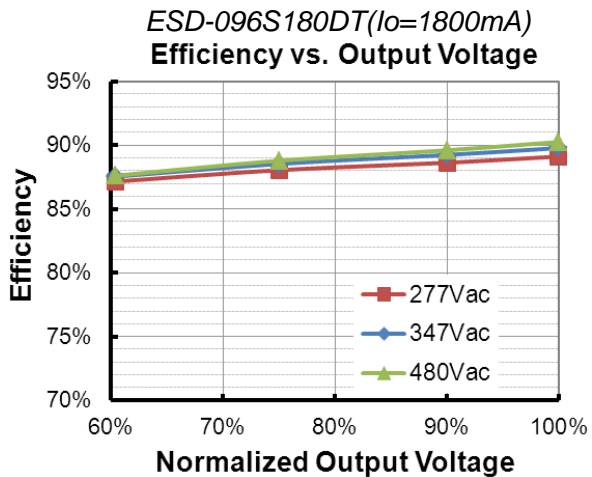
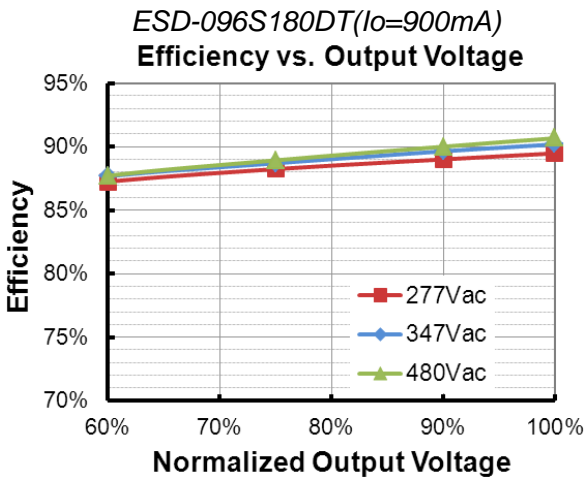
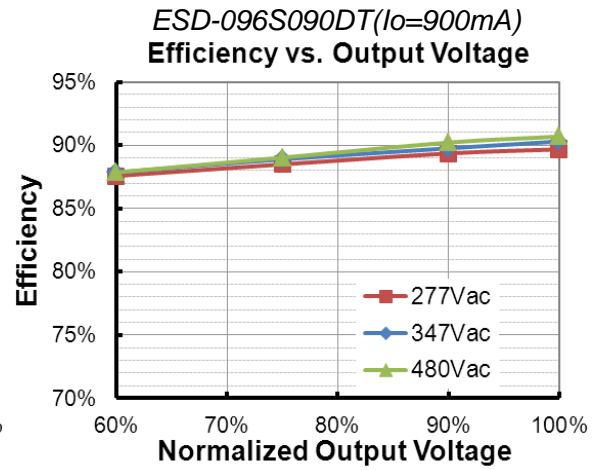
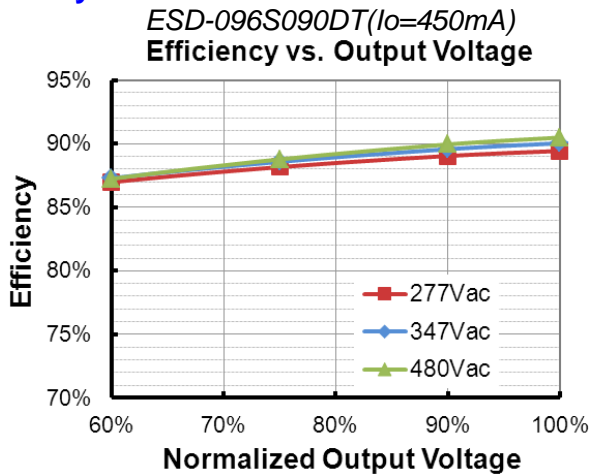

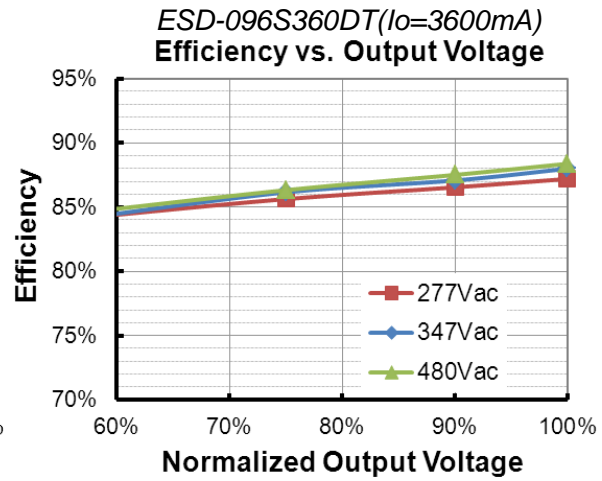
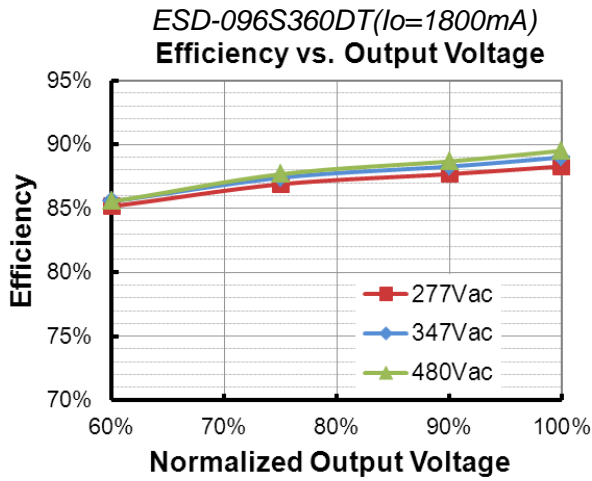

Power Factor

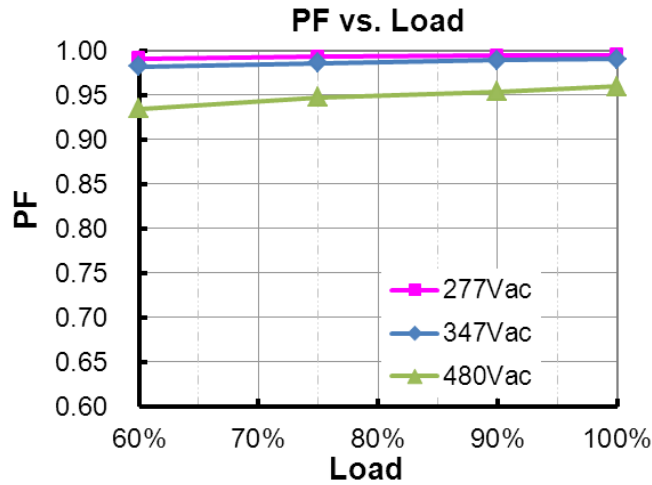

Total Harmonic Distortion

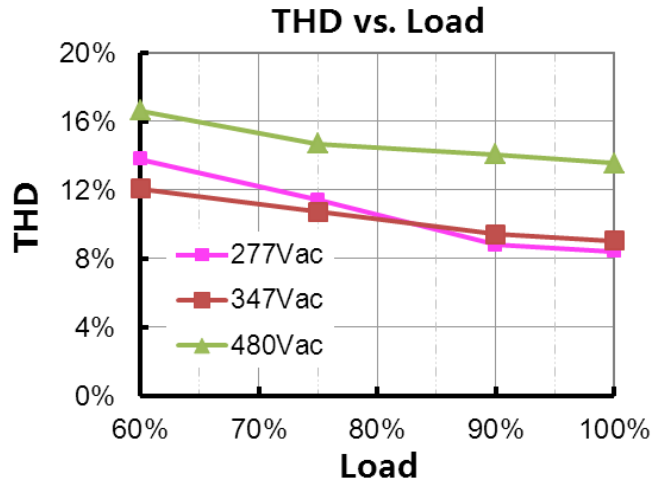

Protection Functions

Parameter	Notes
Over Temperature Protection	Decreases output current, returning to normal after over temperature is removed.
Short Circuit Protection	Auto Recovery. No damage will occur when any output is short circuited. The output shall return to normal within $60 \pm 5s$ after the fault condition is removed.
Over Voltage Protection	Auto Recovery. The power supply shall be self-recovered within $60 \pm 5s$ after the fault condition is removed.

Dimming

● 0-10V Dimming

The recommended implementation of the dimming control is provided below.

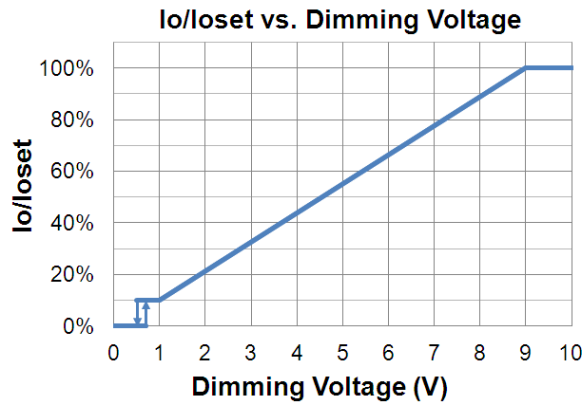
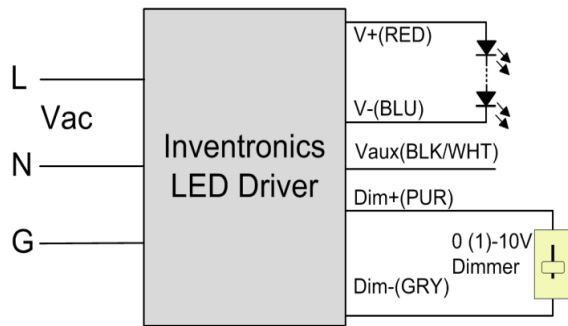

Implementation 1: DC Input

Notes:

1. The dimmer can also be replaced by an active 0-10V voltage source signal or passive components like resistors and zener.
2. Do not connect the GND of dimming to the output; otherwise, the LED driver cannot work normally.
3. If 0-10V dimming is not used, Dim + should be open.

● PWM Dimming

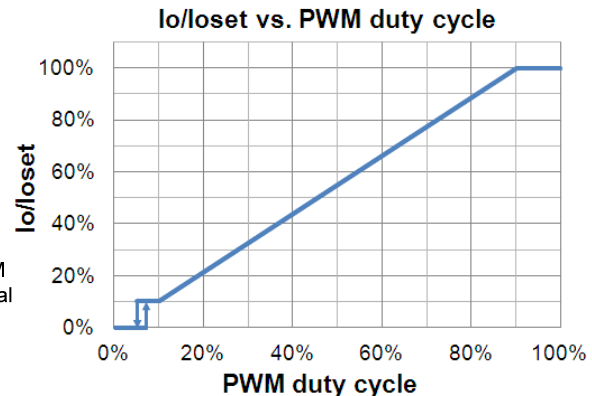
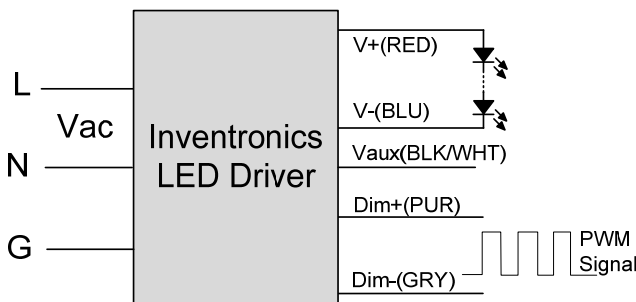

Implementation 2: Positive logic

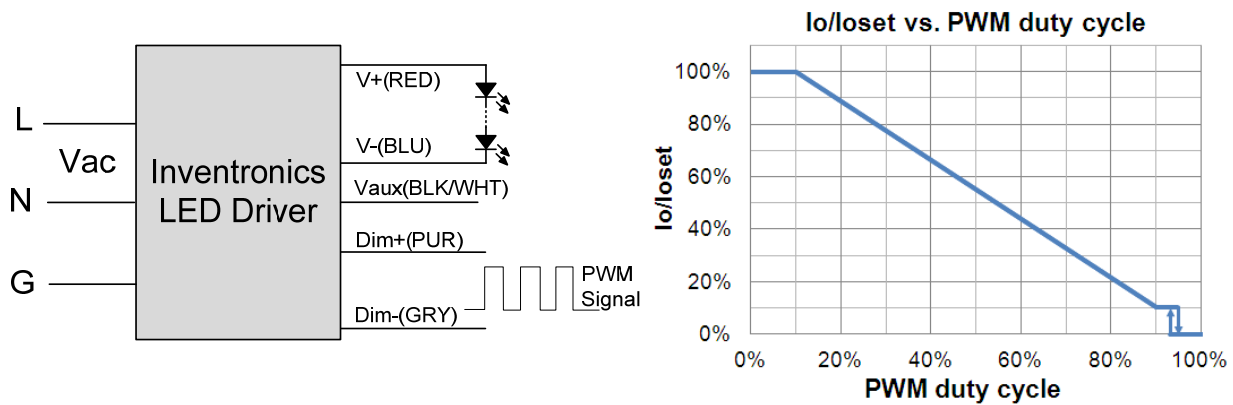

Implementation 3: Negative logic

● Time Dimming

Time dimming control includes 3 kinds of modes, they are Self Adapting-Midnight, Self Adapting-Percentage and Traditional Timer.

- **Self Adapting-Midnight:** Automatically adjusts the dimming curve based on the on-time of past two days (if difference <15 minutes), assuming that the center point of the dimming curve is midnight local time.
- **Self Adapting-Percentage:** Automatically adjusts the on-time of each step by a constant percentage = (actual on-time for the past 2 days if difference <15 min) / (programmed on-time from the dimming curve).
- **Traditional Timer:** Follows the programmed timing curve after power on with no changes.

● Output Lumen Compensation

Output Lumen Compensation (OLC) may be used to maintain constant light output over the life of the LEDs by driving them at a reduced current when new, then gradually increasing the drive current over time to counteract LED lumen degradation.

Programming Connection Diagram

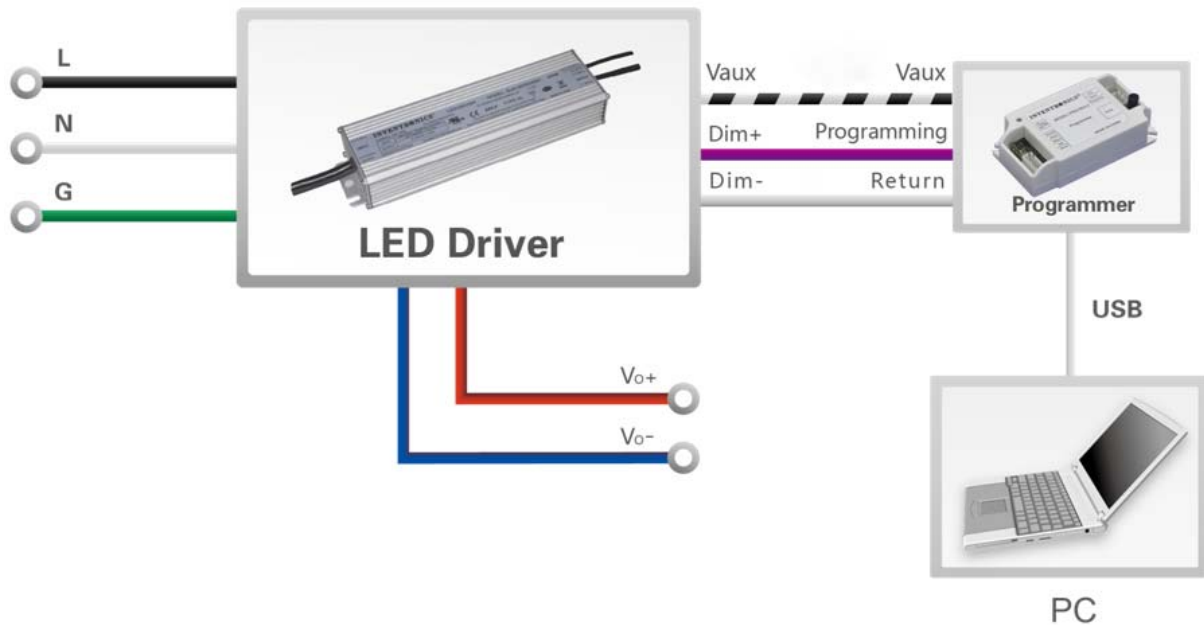

Note: The driver does not need to be powered on during the programming process.

- Please refer to [PRG-MUL2 Multi-Programmer datasheet](#) for details.

Mechanical Outline

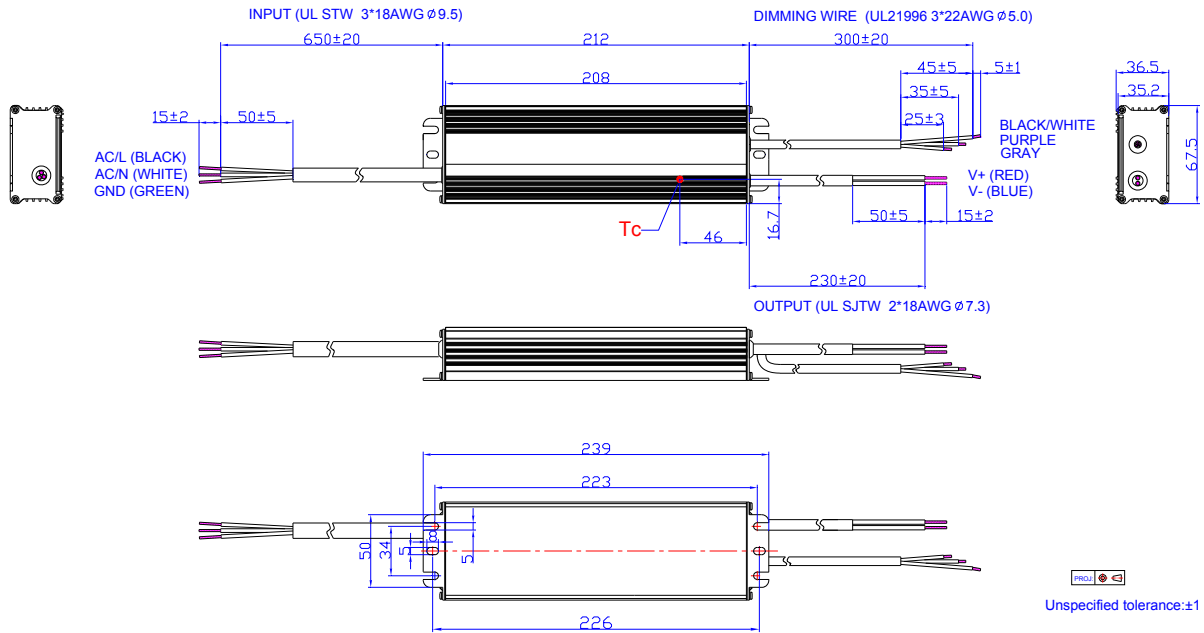

RoHS Compliance

Our products comply with the European Directive 2011/65/EC, calling for the elimination of lead and other hazardous substances from electronic products.

Revision History

Change Date	Rev.	Description of Change		
		Item	From	To
2015-03-09	A	Datasheets Release	/	/
2016-06-30	B	Models	Adjustable Output Current Range	Updated
		I-V Operating Area	/	Updated
		Output Specifications	Output Current Setting(Io _{set}) Range	Updated
		General Specifications	With mounting ear	Updated
		General Specifications	Net Weight	Updated
		Dimming Specifications	Dimming Output Range	Updated
		Safety & EMC Compliance	/	Updated
		Programming Connection Diagram	/	Updated
2017-08-03	C	Mechanical Outline	/	Updated
		Models	/	Updated
		Input Specifications	PF/THD	Updated
		Output Specifications	Turn-on Delay Time	Updated
		Output Specifications	Temperature Coefficient of Io _{set}	Updated
		Safety & EMC Compliance	/	Updated